

VSE100

DIAGNOSTIC ELECTRONICS

Diagnostic systems

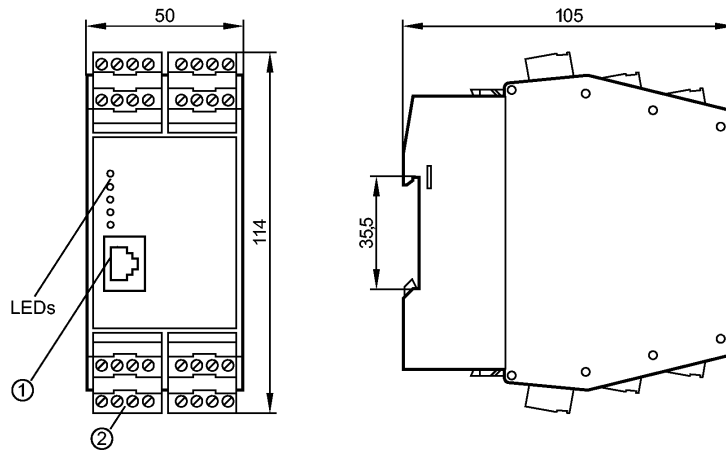

1: Ethernet interface



Product characteristics

Diagnostic electronics for vibration sensors

VSE

Plastic housing

Combicon connection

Integrated history memory with real-time clock

Counter function

TCP/IP Ethernet interface

Active wire break detection and self-test (only MEMS) of the connected acceleration sensors

Parameter setting via PC software VES004

Electrical data

Operating voltage	[V]	24 DC ± 20 % *)
Current consumption	[mA]	200 (24 V)
Protection class		III

Inputs / outputs

Circuit	4 inputs dynamic, can be configured individually: 0...10 mA, IEPE or 0/4...20 mA 2 inputs static: 0/4...20 mA (0...10 V) or pulse (electrically isolated) 2 digital alarm outputs (PNP 100 mA) or 1 digital output and 1 analogue output 0/4...20/22 mA (0...10 V)
Inputs / outputs total	16, configurable
Dynamic (number)	4

Inputs

Dynamic input	0...10 mA, IEPE or 0/4...20 mA
digital	
Circuit	HTL-Pegel
analog	
Input pulses	0/4...20 mA or 0...10 V or pulse
Resolution	[Bit] 12

Outputs

digital	
Output	OU 1 = switching output or analogue output / OU 2 (I/O 1...8) = switching output
Output function	normally open / closed programmable

VSE100

DIAGNOSTIC ELECTRONICS

Diagnostic systems

Max. current load per output	[mA]	100
Voltage drop	[V]	< 2
Short-circuit protection		yes (non-latching)
Overload protection		yes
analog		
current output	[mA]	0/4...20/22; or 0...10 V
Max. load	[Ω]	500

Measuring / setting range

Sampling rate	[kSamples]	≤ 100
---------------	------------	-------

Software / programming

History memory		Ring memory, FIFO (max. 881664 values)
----------------	--	--

Interfaces

Data interface		Ethernet TCP/IP
----------------	--	-----------------

Environment

Ambient temperature	[°C]	0...70
Storage temperature	[°C]	0...70
Protection		IP 20

Tests / approvals

EMC		EN 61000-6-2 EN 61000-6-3 EN 50178
MTTF	[Years]	89

Mechanical data

Max. length of the sensor cable	[m]	250
Housing materials		PA
Type of mounting		Mounting on DIN rail
Weight	[kg]	0.357

Electrical connection

Connection		Combicon
------------	--	----------

Wiring

VSE100

DIAGNOSTIC ELECTRONICS

Diagnostic systems

1: L+ when a VSP acceleration sensor or an IEPE sensor 24 V DC ± 20% is used

9...24: Sensor-specific see operating instructions

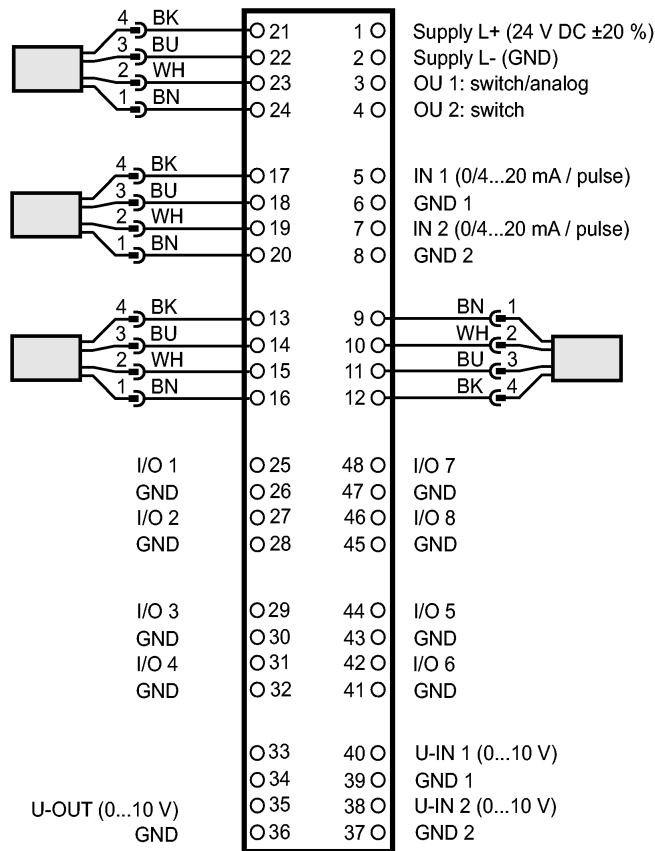

Accessories

Accessories (optional)

crosslink cable for the direct connection of the diagnostic electronics VSExx to the PC Ethernet interface

Remarks

Remarks

*) 24 V + 20% if an IEPE input is used (Integrated Electronics Piezo Electric)

Pack quantity

[piece]

1