

UGT504



Ultrasonic sensor

UGB00800010G/US



1 LEDs



Product characteristics

Sensing range	[mm]	60...800; (Target: 200 x 200 mm)
Housing		Threaded type
Dimensions	[mm]	M18 x 1 / L = 60.5

Electrical data

Operating voltage	[V]	10...30 DC; (cULus - Class 2 source required)
Current consumption	[mA]	< 35
Protection class		III
Reverse polarity protection		yes
Power-on delay time	[s]	< 0.3
Converter frequency	[kHz]	230

Inputs / outputs

Number of inputs and outputs	Number of analog outputs: 1
------------------------------	-----------------------------

Inputs

Synchronization input	no
Multiplex input	no

Outputs

Total number of outputs	1	
Number of analog outputs	1	
Analog current output	[mA]	4...20
Max. load	[Ω]	500
Short-circuit protection		yes
Overload protection		yes

Monitoring range

Sensing range	[mm]	60...800; (Target: 200 x 200 mm)
Blind zone	[mm]	60
Angle of aperture cylindrical	[°]	15; (±2)
Max. deviation from the 90° angle sensor/object	[°]	± 4

UGT504



Ultrasonic sensor

UGB00800010G/US

Accuracy / deviations		
Temperature compensation		yes
Switch-point drift	[%]	-5...5
Linearity error of analog output	[%]	< 1
Notes on the accuracy / deviation	The indicated values are reached after a warm-up time of min. 20 minutes	
Repeatability		1 %
Resolution	[mm]	2
Reaction times		
Response time	[ms]	< 500; (analog output)
Operating conditions		
Ambient temperature	[°C]	-20...70
Storage temperature	[°C]	-30...80
Protection		IP 67
Tests / approvals		
EMC	EN 61000-4-2 ESD	4 kV CD / 8 kV AD
	EN 61000-4-3 HF radiated	3 V/m
	EN 61000-4-4 Burst	2 kV
	EN 61000-4-6 HF conducted	3 V
	EN 55011	class A
Vibration resistance	EN 60068-2-6 Fc	(10-55) Hz 1 mm amplitude, vibration duration 5 min., 30 min. per axis with resonance or 55 Hz
Shock resistance	EN 60068-2-27 Ea	30 g 11 ms half-sine; 3 shocks each in every direction of the 3 coordinate axes
MTTF	[years]	189
UL approval	Ta	-20...70 °C
	voltage supply	Class 2
	File number UL	E174191
Mechanical data		
Weight	[g]	111.2
Housing		Threaded type
Dimensions	[mm]	M18 x 1 / L = 60.5
Thread designation		M18 x 1
Material		stainless steel (1.4404 / 316L); PA; epoxy glass ceramics
Tightening torque	[Nm]	50
Displays / operating elements		
Display	Switching status	1 x LED, yellow
	echo	1 x LED, green
Accessories		
Items supplied		lock nuts: 2, stainless steel
Remarks		
Remarks		cULus - Class 2 source required
Pack quantity		1 pcs.

UGT504



Ultrasonic sensor

UGB00800010G/US

Electrical connection

Connector: 1 x M12; coding: A



Connection

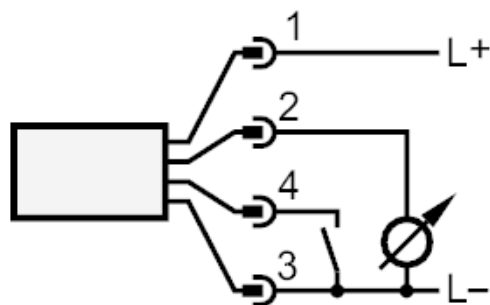

4: Teach

UGT504

Ultrasonic sensor

UGB00800010G/US



Diagrams and graphs

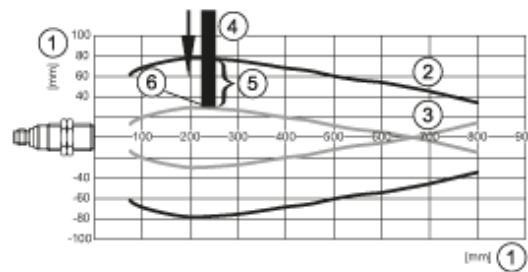
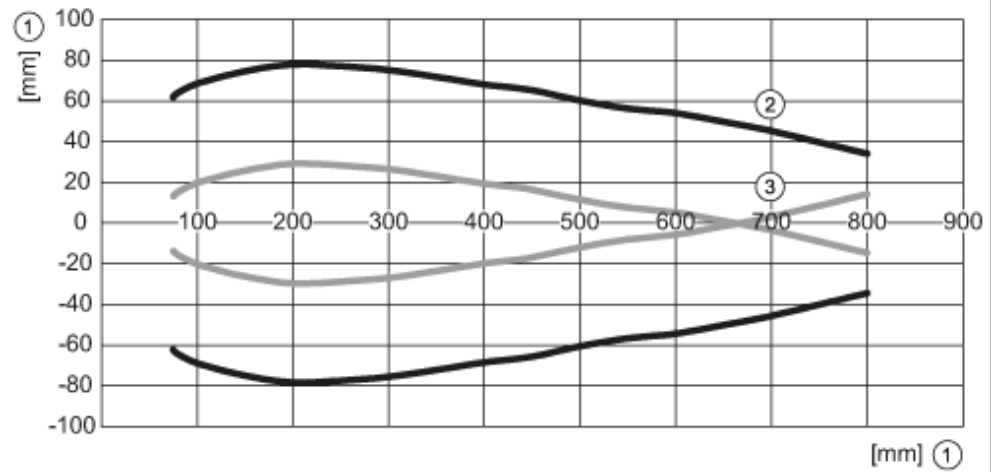

- 1: Distance
- 2: Monitoring range
- 3: switch-on/switch-off graph
- 4: Target 100 x 100 mm
- 5: 50 % of the target in the detection zone
- 6: Set point