

U60017

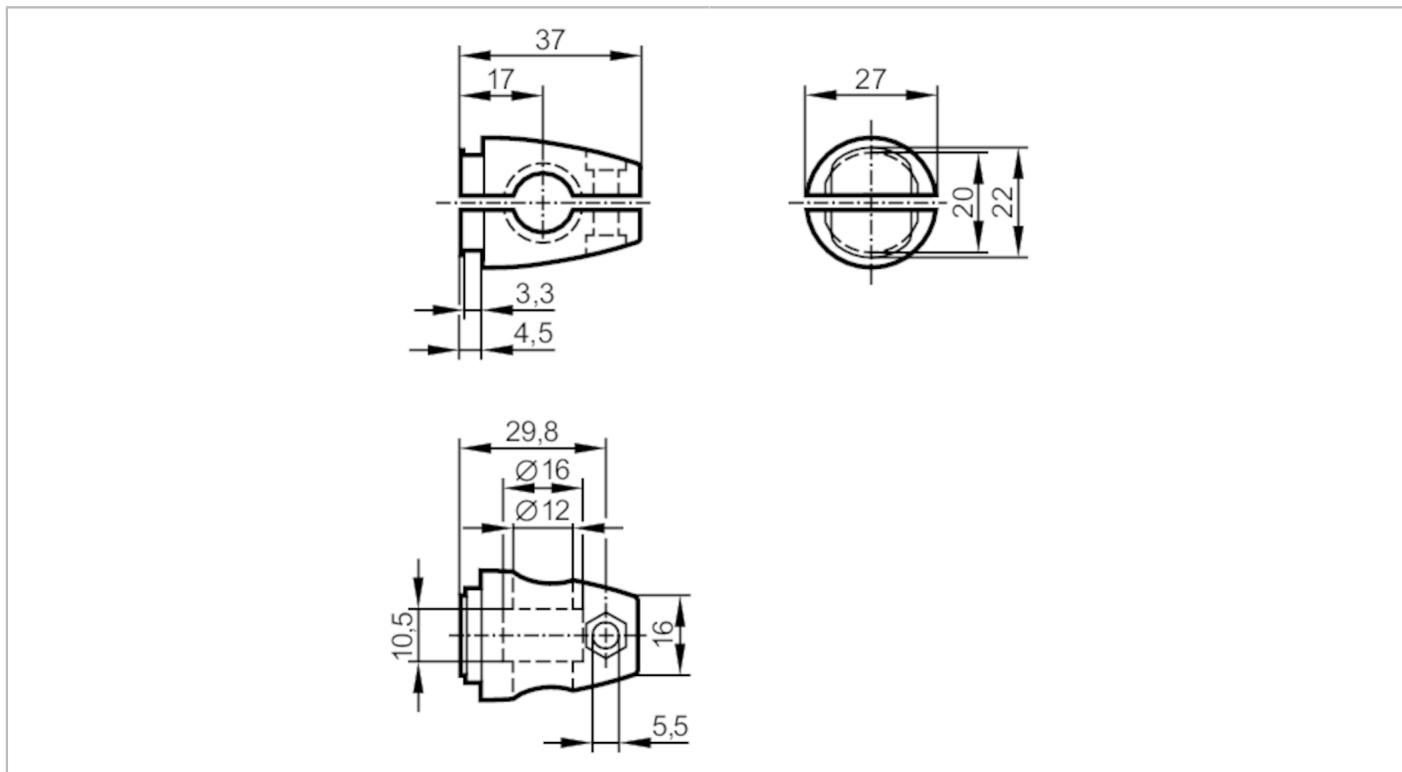

Mounting set for position sensors

BRKT, M18, PROTECTIVE, SWIVEL



Application	
Design	Clamp mounting, with protective cover
Mechanical data	
Weight [g]	308.443
Type of mounting	free-standing; (M10)
Dimensions [mm]	27 x 27 x 37
Material	Clamp: stainless steel (1.4408); fixture: stainless steel
Accessories	
Items supplied	head cap screw: 1 x M10 x 55 Mounting bracket
Remarks	
Pack quantity	1 pcs.