

## SBY234

SBY34IF0FRKG

Flow sensors

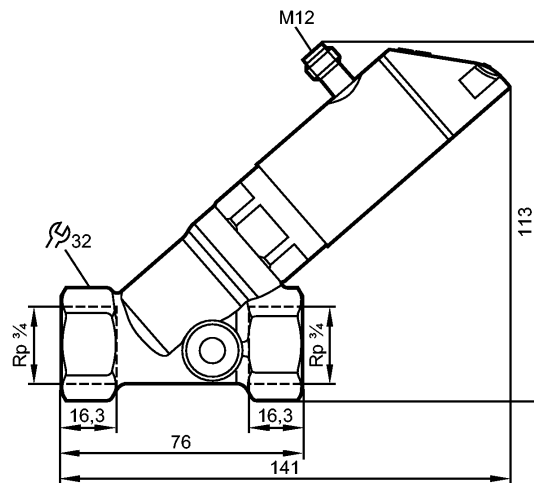

### Product characteristics

Mechatronic flow meter

with non-return valve

Process connection: Rp 3/4

With display (360° rotatable); IO-Link; temperature measurement

### Application

Application	Liquids (water, glycol solutions, coolants, oil (oil 1 with viscosity 10 mm <sup>2</sup> /s at 40 °C; oil 2 with viscosity 46 mm <sup>2</sup> /s at 40 °C)	
Pressure rating [bar]	40	
Medium temperature [°C]	-10...100	

### Electrical data

Electrical design	DC	
Operating voltage [V]	18...30 DC; to DIN EN 50178, SELV, PELV	
Current consumption [mA]	< 50	
Protection class	III	
Reverse polarity protection	yes	

### Outputs

Output function	OUT1: NO / NC programmable or frequency or IO-Link OUT2: NO / NC programmable or analogue	
Current rating [mA]	2 x 150; 2 x 200 (...60 °C); 2 x 250 (...40 °C)	
Voltage drop [V]	< 2	
Short-circuit protection	yes	
Overload protection	yes	
Analog output	4...20 mA	
Max. load [Ω]	500	
Frequency range [Hz]	0...10000	

### Measuring / setting range

Flow monitoring		
Measuring range	1...50 [l/min]	0.06...3 [m <sup>3</sup> /h]
Display range	0...60 [l/min]	0...3.6 [m <sup>3</sup> /h]
Resolution	0.5 [l/min]	0.01 [m <sup>3</sup> /h]
Set point, SP	0.5...50 [l/min]	0.02...3 [m <sup>3</sup> /h]

## SBY234

SBY34IF0FRKG

Flow sensors

Reset point, rP	0...49.5 [l/min]	0...2.98 [m <sup>3</sup> /h]
Frequency end point, FEP	3.5...50 [l/min]	0.2...3 [m <sup>3</sup> /h]
in steps of	0.5 [l/min]	0.01 [m <sup>3</sup> /h]
Frequency at the end point, FrP [Hz]	10...10000	
in steps of	10 Hz	
Measuring dynamics	1:50	
Temperature monitoring		
Measuring range [°C]	-10...100	
Display range [°C]	-32...122	
Resolution [°C]	1	
Set point, SP [°C]	-9...100	
Reset point, rP [°C]	-10...99	
Frequency start point, FSP [°C]	-10...78	
Frequency end point, FEP [°C]	12...100	
in steps of [°C]	1	
Frequency at the end point, FrP [Hz]	10...10000	

### Accuracy / deviations

Flow monitoring		
Accuracy [% of the final value]	$\pm (4 \% MW + 1 \% MEW)$ ; Q > 1 l/min, medium and ambient temperature +22 °C $\pm$ 4 K	
Repeatability	$\pm 1 \% MEW$	

Pressure loss (dP) / flow rate (Q)

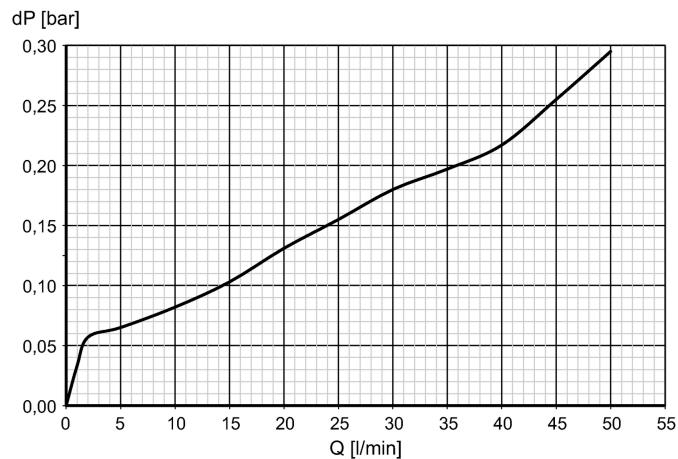

Temperature monitoring		
Accuracy [K]	3 K (25°C; Q > 1 l/min)	
Temperature drift	0.029 °C / K	

### Reaction times

Power-on delay time [s]	< 3	
Flow monitoring		
Response time [s]	0.01	
Damping for the switching output (dAP) [s]	0...5	
Damping for the analog output (dAA) [s]	0...5	
in steps of	0.1 s	
Temperature monitoring		
Response time [s]	T09 = 120 (Q > 1 l/min)	

**SBY234**

SBY34IF0FRKG

**Flow sensors**

**Software / programming**

Programming options	Hysteresis/window; NO/NC; switching logic; current / frequency output; fluid selection, damping switching/analogue output, display can be rotated/switched off; standard unit of measurement/colour process value
---------------------	---

**Interfaces**

IO-Link Device	
Transfer type	COM2 (38.4 kBaud)
IO-Link revision	1.1
SDCI standard	IEC 61131-9 CDV
IO-Link Device ID	562 d / 0232 h
Profiles	Smart Sensor: Process Data Variable; Device Identification
SIO mode	yes
Required master port class	A
Process data analogue	2
Process data binary	2
Min. process cycle time [ms]	5

**Environment**

Ambient temperature [°C]	0...60, at max. 80 °C medium temperature (0...40 °C at max. 100 °C medium temperature)
Storage temperature [°C]	-15...80
Protection	IP 65 / IP 67

**Tests / approvals**

Pressure equipment directive	sound engineering practice
EMC	DIN EN 61000-6-2 DIN EN 61000-6-3
Shock resistance	DIN EN 60068-2-27      20 g (11 ms)
Vibration resistance	DIN EN 60068-2-6      5 g (10...2000 Hz)
MTTF [Years]	145
UL approval number	I005

**Mechanical data**

Process connection	Rp ¾
Materials (wetted parts)	stainless steel 316 / 1.4401; stainless steel 316L / 1.4404; brass (2.0371); brass chemically nickel-plated; PPS; O-ring: FKM
Housing materials	stainless steel 316L / 1.4404; PBT+PC-GF 30; PBT-GF 20; PC; brass chemically nickel-plated
Weight [kg]	0.668
Switching cycles min.	10 million

**Displays / operating elements**

Display	Display unit      3 x LED green Switching status    2 x LED yellow 4-digit alphanumeric display / alternating indication Measured values of red and green Programming      4-digit alphanumeric display
---------	---

**Electrical connection**

Connection	M12 connector; gold-plated contacts
------------	-------------------------------------

**Wiring**

**SBY234**

SBY34IF0FRKG

Core colors  
 BK black  
 BN brown  
 BU blue  
 WH white

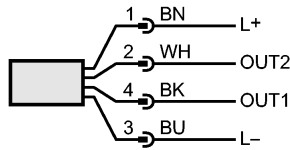

**OUT1:**

- switching output flow rate monitoring
- switching output temperature monitoring
- frequency output flow rate monitoring
- frequency output temperature monitoring
- IO-Link

**OUT2:**

- switching output flow rate monitoring
- switching output temperature monitoring
- analogue output flow rate
- analogue output temperature

-----  
 Colours to DIN EN 60947-5-2

Remarks	
Remarks	Use of 200 micron filtration is recommended. All data refer to water (20 °C). MW = measured value MEW = final value of the measuring range
Pack quantity	1