

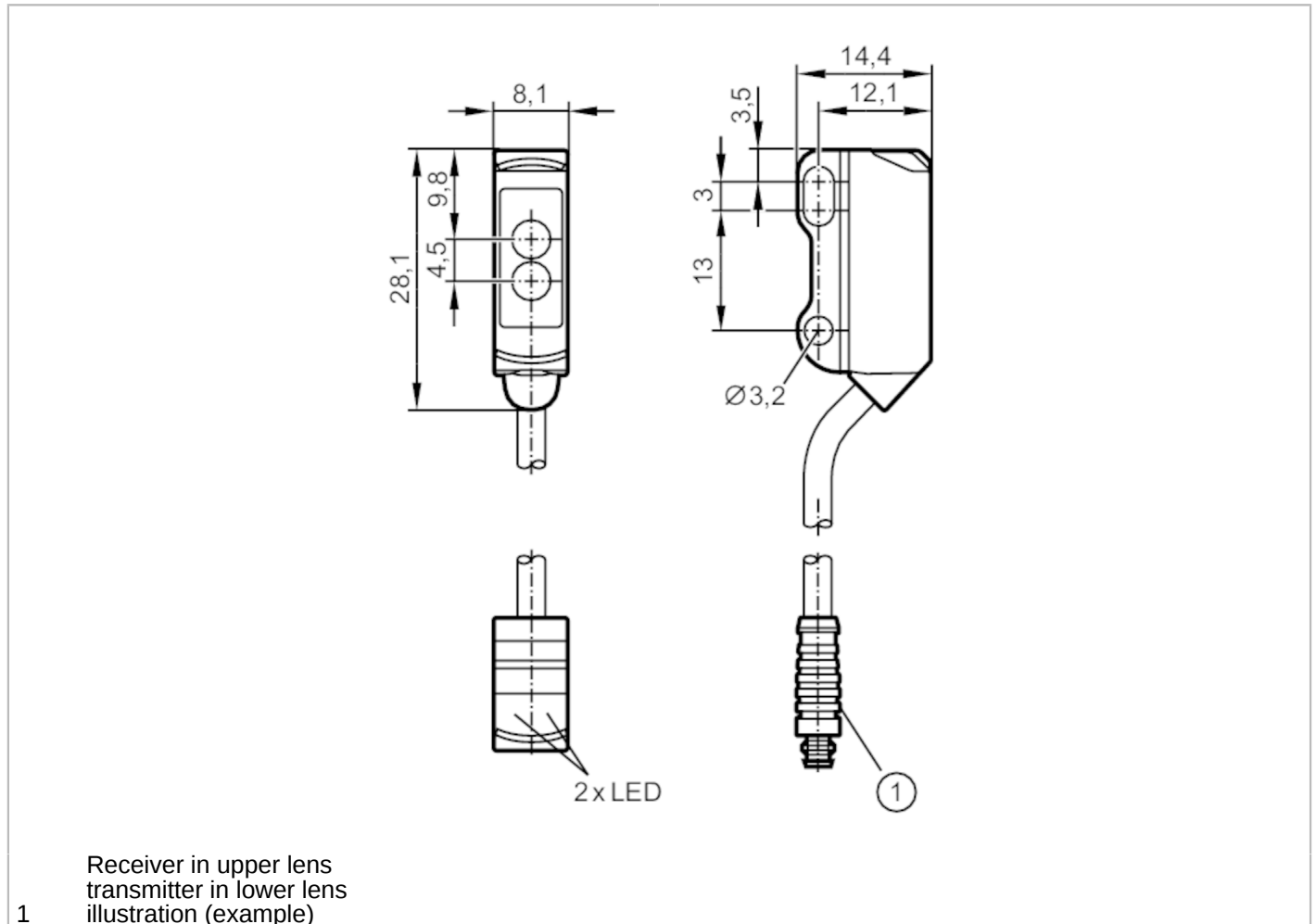

## Diffuse reflection sensor

O8T-FPKG/IO-Link/0,30M/AS/3P



Product characteristics	
Type of light	red light
Housing	rectangular
Application	
Function principle	Diffuse reflection sensor
Electrical data	
Operating voltage [V]	10...30 DC
Current consumption [mA]	20; ((24 V))
Protection class	III
Reverse polarity protection	yes
Type of light	red light
Wave length [nm]	633



## Diffuse reflection sensor

O8T-FPKG/IO-Link/0,30M/AS/3P

Outputs		
Electrical design		PNP
Output function		light-on/dark-on mode; (programmable)
Max. voltage drop switching output DC	[V]	2.5
Permanent current rating of switching output DC	[mA]	100
Switching frequency DC	[Hz]	1000
Short-circuit protection		yes
Type of short-circuit protection		yes (non-latching)
Monitoring range		
Range	[mm]	0...180; (white paper 200 x 200 mm)
Max. light spot diameter	[mm]	18
Light spot dimensions refer to		at maximum range
Interfaces		
Communication interface		IO-Link
Transmission type		COM2 (38,4 kBaud)
IO-Link revision		1.1
SDCI standard		IEC 61131-9
Profiles		Smart Sensor: Device Identification; Device Diagnosis; Teach Channel; Switching Channel
SIO mode		yes
Required master port class		A
Min. process cycle time	[ms]	2.5
IO-Link process data (cyclical)	Function	bit length
	process value	8
	device status	4
IO-Link functions (acyclical)	binary switching information	1
	application specific tag; operating hours counter; switching cycles counter	
Supported DeviceIDs	Type of operation	DeviceID
	default	788
Operating conditions		
Ambient temperature	[°C]	-25...60
Protection		IP 65; IP 67
Tests / approvals		
EMC		EN 60947-5-2
MTTF	[years]	1067
UL approval	Ta	-25...60 °C
	Enclosure type	Type 1
	voltage supply	Limited Voltage/Current
	UL approval number	E017
	File number UL	E174191

# O8T202



## Diffuse reflection sensor

O8T-FPKG/IO-Link/0,30M/AS/3P

### Mechanical data

Weight	[g]	21.2
Housing		rectangular
Dimensions	[mm]	28.1 x 8.1 x 14.4
Material		housing: ABS; stainless steel (1.4404 / 316L)
Lens material		PMMA
Lens alignment		Side sensing

### Displays / operating elements

Display	Switching status	1 x LED, yellow
	Power	1 x LED, green

### Remarks

Pack quantity	1 pcs.
---------------	--------

### Electrical connection

Cable: 0.3 m, PVC, black, Ø 2.9 mm; 3 x 0.08 mm<sup>2</sup>

Connector: 1 x M8; coding: A



### Connection

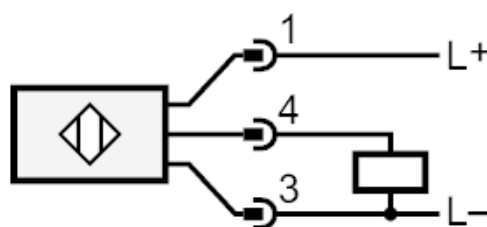



## Diffuse reflection sensor

O8T-FPKG/IO-Link/0,30M/AS/3P

### Diagrams and graphs

excess gain graph

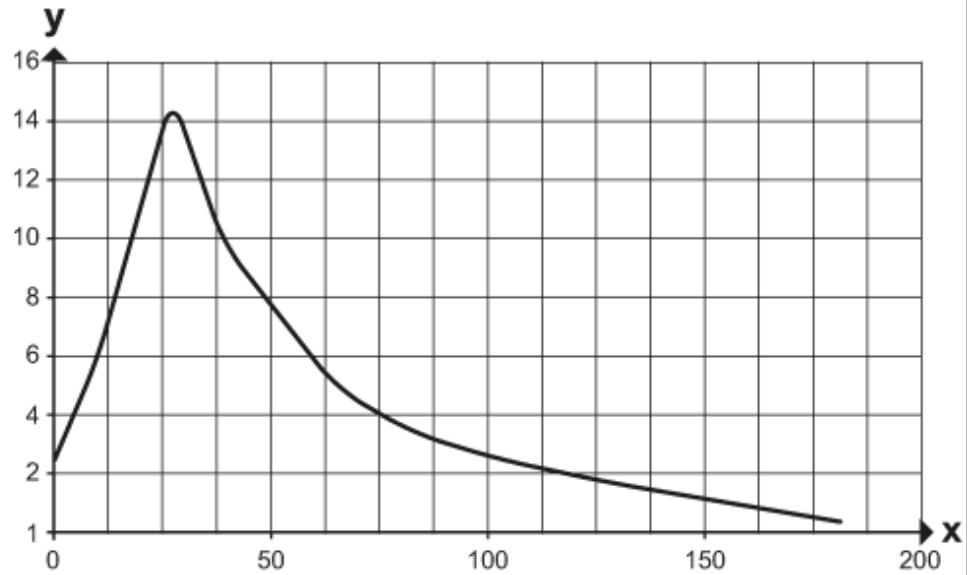

x: distance [mm]

y: excess gain factor